

CLAMPRO®



ELECTRIC IMPACT WRENCH

MODEL NO: CEW1100

PART NO: 6480320

OPERATION & MAINTENANCE INSTRUCTIONS



ORIGINAL INSTRUCTIONS

LS0718 - ISS 2

INTRODUCTION

Thank you for selecting this Clarke impact wrench.

The impact wrench is intended for tightening and loosening nuts, and is equipped with a rotary impact mechanism.

IMPORTANT

Read all instructions carefully before you use this impact wrench. Pay attention to all sections of this user guide that display warning symbols and notices.



WARNING: THIS SYMBOL IS USED THROUGHOUT THE USER GUIDE WHEN THERE IS A RISK OF PERSONAL INJURY. MAKE SURE THAT THESE WARNINGS ARE READ AND UNDERSTOOD AT ALL TIMES.



CAUTION: THIS SYMBOL IS USED THROUGHOUT THE USER GUIDE WHEN THERE IS A RISK OF DAMAGING YOUR IMPACT WRENCH. MAKE SURE THAT THESE CAUTIONS ARE READ AND UNDERSTOOD AT ALL TIMES.

GUARANTEE

The impact wrench is guaranteed against faulty manufacture for a period of 12 months from the date of purchase. Your receipt is required as proof of purchase.

This guarantee is invalid if the impact wrench is found to have been abused, tampered with, or not used for the purpose for which it was intended.

Faulty goods must be returned to their place of purchase, it must not be returned to us without prior permission.

This guarantee does not effect your statutory rights.

GENERAL POWER TOOL SAFETY WARNINGS



WARNING: READ ALL SAFETY WARNINGS AND ALL INSTRUCTIONS. FAILURE TO FOLLOW THE WARNINGS AND INSTRUCTIONS MAY RESULT IN ELECTRIC SHOCK, FIRE AND/OR SERIOUS INJURY.

Save all warnings and instructions for future reference.

The term "power tool" in the warnings refers to your mains-operated impact wrench

WORK AREA SAFETY

1. **Keep work area clean and well lit.** Cluttered or dark areas invite accidents.
2. **Do not operate power tools in explosive atmospheres, such as in the presence of flammable liquids, gases or dust.** Power tools create sparks which may ignite the dust or fumes.
3. **Keep children and bystanders away while operating a power tool.** Distractions can cause you to lose control.

ELECTRICAL SAFETY

1. **Power tool plugs must match the outlet. Never modify the plug in any way. Do not use any adapter plugs with earthed (grounded) power tools.** Unmodified plugs and matching outlets will reduce risk of electric shock.
2. **Avoid body contact with earthed or grounded surfaces, such as pipes, radiators, ranges and refrigerators.** There is an increased risk of electric shock if your body is earthed or grounded.
3. **Do not expose power tools to rain or wet conditions.** Water entering a power tool will increase the risk of electric shock.
4. **Do not abuse the cord. Never use the cord for carrying, pulling or unplugging the power tool. Keep cord away from heat, oil, sharp edges or moving parts.** Damaged or entangled cords increase the risk of electric shock.
5. **When operating a power tool outdoors, use an extension cord suitable for outdoor use.** Use of a cord suitable for outdoor use reduces the risk of electric shock.
6. **If operating a power tool in a damp location is unavoidable, use a residual current device (RCD) protected supply.** Use of an RCD reduces the risk of electric shock.

PERSONAL SAFETY

1. **Stay alert, watch what you are doing and use common sense when operating a power tool. Do not use a power tool while you are tired or under the influence of drugs, alcohol or medication.** A moment of inattention while operating power tools may result in serious personal injury.
2. **Use personal protective equipment. Always wear eye and ear protection.** Protective equipment such as dust mask, non-skid safety shoes, hard hat, or hearing protection used for appropriate conditions will reduce personal injuries.
3. **Prevent unintentional starting. Ensure the switch is in the off position before connecting to power source, picking up or carrying the tool.** Carrying power tools with your finger on the switch or energising power tools that have the switch on invites accidents.
4. **Remove any adjusting key or wrench before turning the power tool on.** A wrench or a key left attached to a rotating part of the power tool may result in personal injury.
5. **Do not overreach. Keep proper footing and balance at all times.** This enables better control of the power tool in unexpected situations.
6. **Dress properly. Do not wear loose clothing or jewellery. Keep your hair, clothing and gloves away from moving parts.** Loose clothes, jewellery or long hair can be caught in moving parts.
7. **If devices are provided for the connection of dust extraction and collection facilities, ensure these are connected and properly used.** Use of dust collection can reduce dust-related hazards.
8. **Hold power tool by insulated gripping surfaces, when performing an operation where the fastener may contact hidden wiring or its own cord.** Fasteners contacting a "Live" wire may make exposed metal parts of the power tool "Live" and could give the operator an electric shock.

POWER TOOL USE AND CARE





1. **Do not force the power tool. Use the correct power tool for your application.** The correct power tool will do the job better and safer at the rate for which it was designed.
2. **Do not use the power tool if the switch does not turn it on and off.** Any power tool that cannot be controlled with the switch is dangerous and must be repaired.
3. **Disconnect the plug from the power source and/or the battery pack from the power tool before making any adjustments, changing accessories, or storing power tools.** Such preventive safety measures reduce the risk of starting the power tool accidentally.

4. **Store idle power tools out of the reach of children and do not allow persons unfamiliar with the power tool or these instructions to operate the power tool.** Power tools are dangerous in the hands of untrained users.
5. **Maintain power tools. Check for misalignment or binding of moving parts, breakage of parts and any other condition that may affect the power tool's operation. If damaged, have the power tool repaired before use.** Many accidents are caused by poorly maintained power tools.
6. **Keep cutting tools sharp and clean.** Properly maintained cutting tools with sharp cutting edges are less likely to bind and are easier to control.
7. **Use the power tool, accessories and tool bits etc. in accordance with these instructions, taking into account the working conditions and the work to be performed.** Use of the power tool for operations different from those intended could result in a hazardous situation.

SERVICE

1. **Have your power tool serviced by a qualified repair person using only identical replacement parts.** This will ensure that the safety of the power tool is maintained.

SAFETY SYMBOLS

	<p>Read instruction manual before use</p>		<p>Wear protective gloves</p>
	<p>Wear safety glasses</p>		<p>Wear ear defenders</p>

ELECTRICAL CONNECTIONS



WARNING: READ THESE ELECTRICAL SAFETY INSTRUCTIONS FULLY BEFORE CONNECTING THE IMPACT WRENCH TO THE MAINS SUPPLY.

This impact wrench is provided with a standard 13 amp, 230 volt (50Hz), BS 1363 plug, for connection to a standard, domestic electrical supply. Should the plug need changing, make sure that a plug of identical specification is used.



**WARNING: THE WIRES IN THE CABLE ARE COLOURED AS FOLLOWS:
BLUE = NEUTRAL BROWN = LIVE**

If the colours of the wires in the power cable do not correspond with the markings on the terminals of your plug, proceed as follows.

- Connect the **blue** wire to the terminal which is marked **N**.
- Connect the **brown** wire to the terminal which is marked **L**.

Plug must be BS1363/A approved.

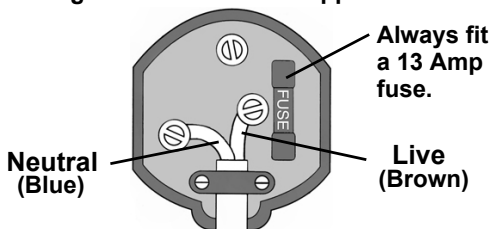

make sure that that the outer sheath of the cable is firmly held by the clamp

We recommend that this machine is connected to the mains supply via a Residual Current Device (RCD)

If in doubt, consult a qualified electrician. DO NOT attempt any repairs yourself



This symbol indicates that this is a Class II product, and does not require an earth connection.

CABLE EXTENSION

Always use an approved cable extension suitable for the power rating of this tool (see specifications), the conductor size should also be at least the same size as that on the machine, or larger. When using a cable reel, always unwind the cable completely

OVERVIEW

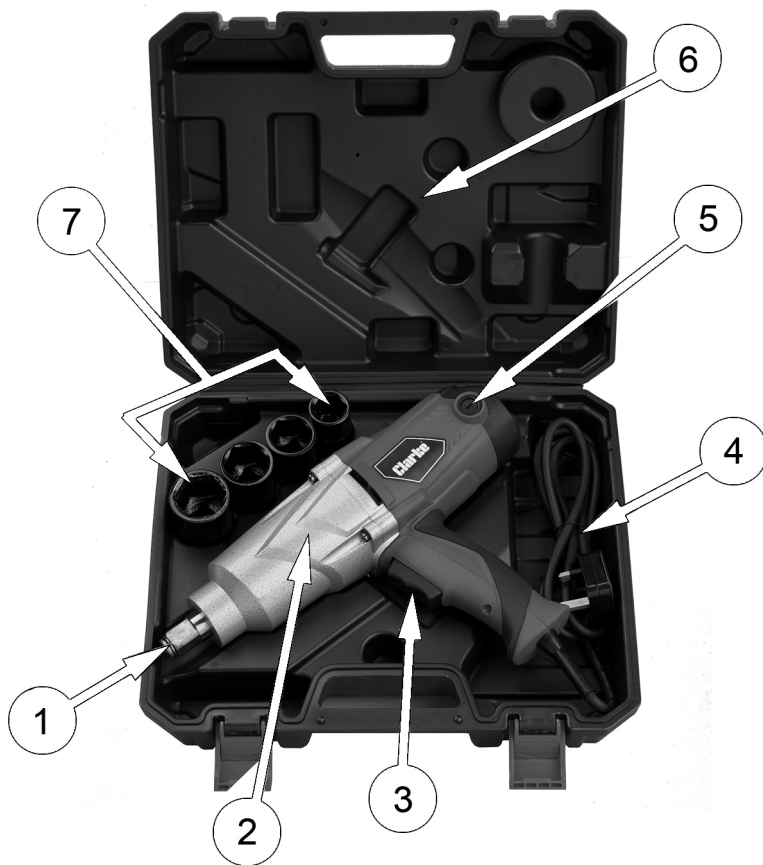

1	3/4" Square Drive	5	Carbon Brush Holder Covers
2	Body	6	Case
3	Direction Switch / Trigger	7	Sockets (24, 30, 32 & 36 mm)
4	Mains Cable		

**ONLY SPECIAL SOCKETS THAT ARE DESIGNED FOR IMPACT TOOLS
SHOULD BE USED WITH THIS IMPACT WRENCH.
STANDARD SOCKETS MAY SHATTER.**

OPERATING INSTRUCTIONS



WARNING: ALWAYS MAKE SURE THAT THE IMPACT WRENCH IS DISCONNECTED FROM THE POWER SUPPLY BEFORE CHANGING THE SOCKET.

WARNING: WHEN CHANGING DIRECTION ALWAYS MAKE SURE THAT THE IMPACT WRENCH HAS STOPPED BEFORE SWITCHING TO THE OTHER DIRECTION.

ATTACH / REMOVE A SOCKET

1. Place the applicable socket on the square drive of the impact wrench.



CAUTION: MAKE SURE THAT THE CORRECT SOCKET IS BEING USED. AN INCORRECT SOCKET IS LIKELY TO DAMAGE THE HEADS OF THE BOLTS OR NUTS.

2. To remove a socket, pull it off of the square drive.

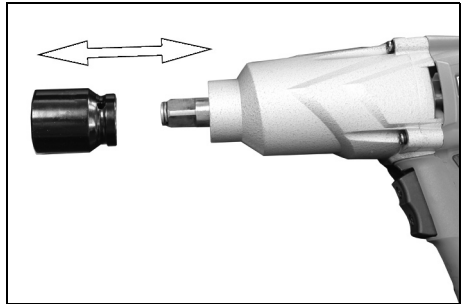

LOOSENING A NUT

1. Place the socket over the nut or bolt head
2. Use two hands to hold the wrench tightly and squeeze the direction switch in the REVERSE (R) position.
 - The nut/bolt will be hit again and again until it is loosened.

IMPORTANT: Release the trigger when the nut starts to loosen.

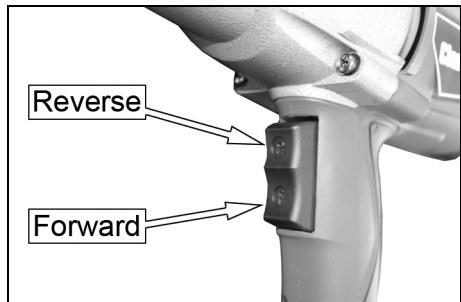

TIGHTENING A NUT

1. Start the nut or bolt by hand to make sure that it is not cross threaded, then with the applicable socket installed on the wrench, place it over the nut or bolt head.
2. Use two hands to hold the wrench tightly and squeeze the direction switch in the FORWARD (F) position.
3. ALWAYS finish tightening with a torque wrench or suitable spanner.

MAINTENANCE AND SERVICING

STORAGE

1. Make sure that the impact wrench is stored in a clean, dry place, out of reach of children when not in use.
2. Always store the impact wrench and its sockets in the case supplied.

CLEANING

1. Always examine the tool before use and make sure that it is in good condition.
2. Make sure that all air vents are clear, (use compressed air to clean the impact wrench if possible).
3. Do not use solvents to clean plastic parts, most plastics are damaged by solvents.

GENERAL MAINTENANCE

1. Make sure that all nuts, bolts and screws are tight.
2. Refer to your CLARKE dealer if internal maintenance is necessary .
3. Make sure that the power cable is free from cracks, bare wires etc .
4. If it is necessary to replace the power cable, this must be done by the manufacturer.
5. The bearings in this tool are lubricated for the tools lifetime in usual operating conditions, no more lubrication is necessary.

ENVIRONMENTAL PROTECTION



Through purchase of this tool, the customer is taking on the obligation to deal with the WEEE in accordance with the WEEE regulations in relation to the treatment, recycling & recovery and environmentally sound disposal of the WEEE.

In effect, this means that this tool must not be discarded with general waste. Refer to the laws governing Waste Electrical and Electronic Equipment (WEEE) at a recognised disposal facility.

REPLACE THE CARBON BRUSHES

1. Use a screwdriver to remove the carbon brush holder covers from the machine body

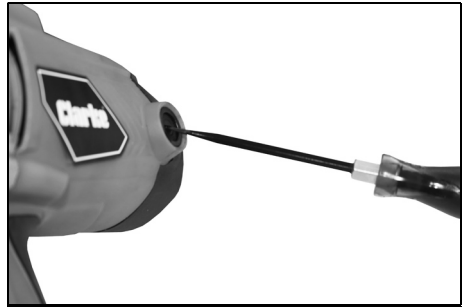

2. Remove and examine the carbon brushes after long periods of operation.

3. Replace them when they have worn down.

- The brushes must be kept clean and free to move up and down in the holders.
- Both brushes must be replaced at the same time.
- Only use brushes supplied by your Clarke dealer.

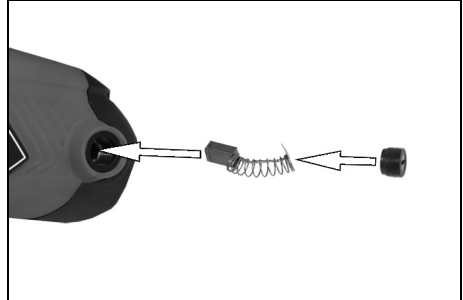

4. Replace the carbon brush holder covers.

SPECIFICATIONS

Item	Item Specification
Model	CEW1100
Weight	4.6 kg
Dimensions	342 x 98 x 230 mm
Voltage	230v / 50 Hz
Max Power Output	1.1 kw
No-load Speed	0-2200 rpm
Max Torque	710 Nm
Sound Pressure	89 dB(A)
Sound Power	100 dB LpA
Vibration	10.4 m/s ²
Uncertainty Factor (K)	1.5m/s ²

DECLARATION OF CONFORMITY



Clarke[®]
INTERNATIONAL

Hemnal Street, Epping, Essex CM16 4LG

DECLARATION OF CONFORMITY

This is an important document and should be retained.

We hereby declare that this product(s) complies with the following directive(s):

2014/30/EU *Electromagnetic Compatibility Directive.*
2006/42/EC *Machinery Directive.*
2011/65/EU *Restriction of Hazardous substances.*

The following standards have been applied to the product(s):

*EN 60745-1:2009+A11, EN 60745-2-2:2010, EN 55014-1:2006+A1+A2, EN 55014-2:2015,
EN 61000-3-2:2014, EN 61000-3-3:2013.*

The technical documentation required to demonstrate that the product(s) meet(s) the requirement(s) of the aforementioned directive(s) has been compiled and is available for inspection by the relevant enforcement authorities.

The CE mark was first applied in: 2018

Product Description: 1100W Corded Impact Wrench
Model number(s): CEW 1100
Serial / batch Number: N/A
Date of Issue: 26/03/2018

Signed:

J.A. Clarke
Director

A SELECTION FROM THE VAST RANGE OF

Clarke®

QUALITY PRODUCTS

AIR COMPRESSORS

From DIY to industrial, Plus air tools, spray guns and accessories.

GENERATORS

Prime duty or emergency standby for business, home and leisure.

POWER WASHERS

Hot and cold, electric and engine driven - we have what you need

WELDERS

Mig, Arc, Tig and Spot. From DIY to auto/industrial.

METALWORKING

Drills, grinders and saws for DIY and professional use.

WOODWORKING

Saws, sanders, lathes, mortisers and dust extraction.

HYDRAULICS

Cranes, body repair kits, transmission jacks for all types of workshop use.

WATER PUMPS

Submersible, electric and engine driven for DIY, agriculture and industry.

POWERTOOLS

Angle grinders, cordless drill sets, saws and sanders.

STARTERS/CHARGERS

All sizes for car and commercial use.

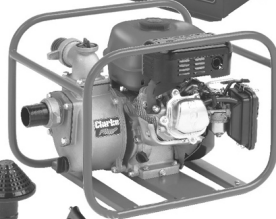

PARTS & SERVICE: 0208 988 7400

E-mail: Parts@clarkeinternational.com or Service@clarkeinternational.com

SALES: UK 01992 565333 or Export 00 44 (0)1992 565335

Clarke® INTERNATIONAL Hemnall Street, Epping, Essex CM16 4LG
www.clarkeinternational.com